

THE INFLUENCE OF TRAINING ROLES, SELF-EFFICACY, CREATIVE PROBLEM-SOLVING ON IMPROVING EMPLOYEE PERFORMANCE

Afifah Gusti Layyinah

Faculty Economic, Universitas Sarjanawiyata Tamansiswa Yogyakarta

Afifahgustilayyinah08@gmail.com

Didik Subiyanto

Faculty Economic, Universitas Sarjanawiyata Tamansiswa Yogyakarta

Didiks@ustjogja.ac.id

Article Info	Abstract
<p>Article History</p> <p>Received: 28 January 2022</p> <p>Accepted: 12 February 2022</p> <p>Published: 29 June 2022</p>	<p><i>Employee performance is an essential component of comparing a company with its employees to achieve productive and efficient results. It can be found in any organization, especially in the Bantul Trade Service. This quantitative study aims to find information about training, self-efficacy, creative problem solving on the performance of employees in the Bantul Trade Service. At the same time, 57 employees were involved in the study, with 34 state civil apparatus and 30 contract employees. The research procedure used a sample saturated with the amount available. The information collected by the questionnaire was then processed and evaluated using SPSS 24, a descriptive statistical system. The findings of this study show that the training does not have a positive or significant impact on the performance of employees at the Bantul trade service. The absence of training offered by the Department to each employee affects this issue. Self-efficacy and creative problem solving, on the other hand, have a beneficial and considerable impact on employee performance. To improve employee performance at the Bantul Trade Office, training, self-efficacy, and creative problem solving must be maximized through suitable training and education for staff.</i></p>
<p>Keywords: Training, Self-Efficacy, Creative Problem-Solving, Employee Performance</p>	

INTRODUCTION

Acquiring superior resources is a very profitable thing for the organization. Superior resources are the most important energy so that organizations can win the competition. Supported by Shaukat et al., (2015) human resources are a significant source of energy for companies. Human resources in a company are the driving force for all activities carried out by the company (Elisa & Sari, 2014). Employees performing well at work are important and valuable assets for any company. Consequently, the availability of the right people at the right time is critical to the success

and survival of the organization. Employees contribute to the growth of the organization by performing assignments to the best of their ability. Without good human resources, it is impossible for an organization to win the competition. To improve employee competence, organizations need education and training programs with the aim of improving performance and improving the quality of human resources. Various training programs within the organization, both off-the-job training and on-the-job training (Azis & Rahardjo, 2021).

Training is necessary because it relates to the skills and abilities of employees in carrying out their current work. Employee training is an organizational planned activity with the function of developing employees and increasing knowledge and skills, especially new knowledge and skills. The purpose of employee training is to improve quality, support human resource planning and also increase productivity. Several previous studies have explained that job training has a significant positive effect on employee performance (Annalia, 2020; Elisa & Sari, 2014; Yusnita & Fadhil, 2015).

In addition to the training quality factor, the employee creativity factor has an important role in improving employee performance as in the research conducted by (Indrajita et al., 2021). Employee creativity is as a form of creative thinking and the ability to see various possibilities in solving a problem. Employee creativity is a form of thinking or ideas, but until now it has received less attention (Indrajita et al., 2021). According to Juwono & Wangsadinata, (2010) creativity can be in the form of process or person. Creativity in the form of processes is indicated in the form of new work, ability to solve problems, and openness to new experiences, while creativity inherent in individuals is in the form of self-confidence, flexibility in thinking and acting.

This study purposes to raise the influence of the factors of training roles, creativity in solving problems and self-efficacy in improving employee service performance. Self-efficacy is a strong belief that a person has about his or her chances of successfully accomplishing a particular task. Individuals with high self-efficacy will achieve a better performance because the individual has a strong motivation to succeed, clear goals, and with a stable emotional level so that this behavior will encourage him to succeed. (Ardi et al., 2017).

LITERATURE REVIEW

Training

Barba Aragón, Jiménez Jiménez, and Sanz Valle (2014) training is an attempt to enhance the quality of human energy sources so that workers may better perform their tasks and grasp the information given by the company. Staff training plays both an activity and a critical role in achieving high-quality, adaptable team member performance. This is unquestionably beneficial in terms of increasing the team member's abilities, talents, and conduct. Several factors may influence

training, according to Widyawaty Mashar (2014) including candidates, training/instructors, training facilities, curriculum, and training funds.

Self-Efficacy

Zaki et al. (2019) human capital is honed, polished, improved, and renewed overtime via training and development encouragement, allowing them to meet the difficulties that they face. The three fundamental signals for human performance are expertise, motivation, and environmental factors. The performance model lists this whole human viewpoint, as well as a new component of self-efficacy. Self-Efficacy is the precursor to commitment and performance of current resources, according to Beattie et al. (2016) his self-efficacy hypothesis has been used to forecast people's views about their capacity to demonstrate abilities at a given level of performance. This theory is based on four primary sources: vicarious experience, success experience, persuasion, and physiological and emotional circumstances. Increased confidence in one's ability to succeed motivates people to take on more challenging objectives and tasks, resulting in higher advanced performance levels, according to a slew of meta-analyses performed across a wide variety of fields. More than 93 percent of studies have shown a favorable relationship between self-efficacy and performance at the individual level (Sitzmann & Yeo, 2013).

Creative Problem Solving

The process of nonconformity between the outcomes achieved and the intended results may be described as a creative issue solution (Hidayatun, 2016). According to Antonio et al. (2014) it may help workers think freely and discover possibilities that contribute positively to the organization's growth. Not only that, but creativity may include a variety of factors, including:

- a) Fluency: a notion or concept that is meaningful and relevant in meeting the needs of a specific environment.
- b) Flexibility: the ability to deconstruct issues and discover additional answers using flexible thinking methods.
- c) Originality: Employees come up with innovative ideas.
- d) Elaboration: The capacity to interpret and enhance more complicated concepts is referred to as elaboration. A team member's inventiveness is also something that can hone.

Employee Performance

Team member accomplishment Widyawaty Mashar (2014) measures a team member's performance in completing tasks assigned or provided by a company based on their experience, abilities, and time. According to Kurniawan (2019), it is a mix of two essential factors: internal factors linked to the team member's character and external factors related to the team member's performance. Team member A, for example, has a high level of skill and therefore performs well.

Team member A, in this instance, belongs to the category of diligent workers. On the other hand, they have poor performance due to a lack of skill and do not enhance their talents. Team member B falls into the category of slackers in this situation. On the other hand, it may be immediately linked to the team member's immediate surroundings. This may be observed in coworkers, behaviors, and actions of coworkers, subordinates, or leaders, and the workplace environment and climate.

Hypotheses

The Importance of Training in Increasing Employee Performance

This study utilizes multiple linear regression analysis to determine the degree of the impact of work training on team member performance. This research reveals that work training factors do not have a substantial beneficial impact on team member performance. In line with the research of Yusnita & Fadhil, (2015) it reveals that factors affecting employee performance is employee training. Training as an important activity for organizations to be able to improve the knowledge, skills and expertise of employees in the company. Supported by Hertomo, Nurul Khastelia; Luturlean, (2020) several PT Pos Indonesia training programs, for example: upgrading training, regular training, and new employee orientation, are training programs selected based on a priority scale to support employee insight and knowledge and ultimately help employees improve performance.

H1: On-the-job training has no discernible impact on increasing team member performance.

The Importance of Self-Efficacy in Employee Performance

Self-efficacy refers to a person's ability to make decisions, their attempts to advance, the tenacity and intensity with which they face challenges, as well as the level of anxiety or calmness with which they maintain sufficient life duties (Sawitri et al., 2018). As a result, team member performance is positively influenced by self-efficacy. Reinforced by Noviawati, (2016) Self efficacy leads to individual judgments and individual efforts to achieve something. Self-efficacy describes how hard and strong a person tries to achieve the required effort and ultimately can be seen from his/her performance. Khaerana, (2020) argues that there are three dimensions in self-efficacy; first is magnitude. It depicts how strong a person is able to face various difficulties. Second is strength. It is someone who persists in his business, and has tenacity in trying. Third is generality showing that although expectations are limited, but the work is still being done. The results indicate that self-efficacy has a positive and significant effect on employee performance at the Secretariat of the Regional General Election Commission (KPUD) of East Luwu Regency.

H2: Self-efficacy improves team member performance favorably and substantially.

The Impact of Problem-Solving Creativity on Employee Performance

According to the findings of multiple linear regression analysis, it demonstrates that problem-solving creativity has a favorable and substantial impact on team member performance; this implies that a team member's ability to change their performance is affected by their inventiveness. The greater a team member's degree of creativity, the better the team member's performance in addressing issues. Research Indrajita et al., (2021) reveals that innovation and creativity have the greatest influence in improving employee performance. Reinforced by Rohayuningsih et al., (2015) related to the decision-making process, creative thinking is needed, especially in identifying problems and developing alternative solutions. Creative thinking will ultimately improve decision-making performance.

H3: Creative issue solving improves team member performance favorably and substantially.

The impact of training roles, self-efficacy, and creative problem solving on increasing team member performance at the same time

The impact of the position above on team member accomplishment may guarantee an organization's success in increasing individual and team performance. In line with the research of Saragih & Siahaan, (2021), creativity and self-efficacy improve simultaneously on service performance. Confidence in one's own abilities, enthusiasm and perseverance in carrying out work, as well as being open to new experiences and being confident in one's abilities are factors encouraging a person to succeed and have quality performance.

H4: Training, Self-Efficacy, and Problem-Solving Creativity of Employee performance are influenced by simultaneous problem-solving favorably and substantially.

Picture 1. Research Framework

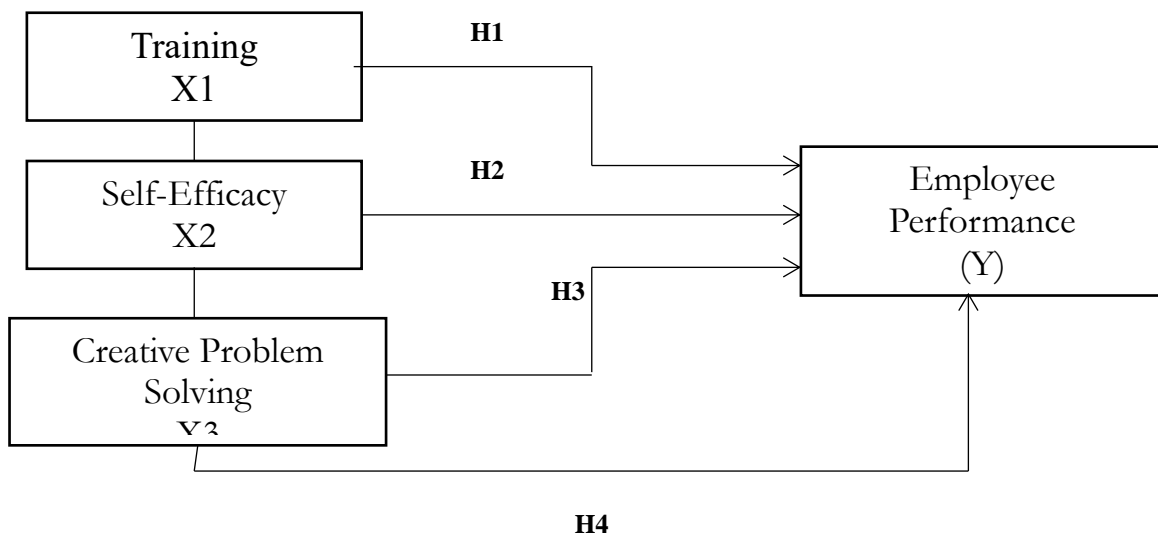

METHODOLOGY

Nature of Research

This technique used to investigate specific populations and samples, sampling procedures, data collecting, and quantitative and statistical data analysis. This descriptive study explains an item tied to population truth to get universally applicable findings. This study investigates the effect of training roles, self-efficacy, and creative problem solving on improving team member performance by gathering data on the ground utilizing a more traditional approach. An explanatory survey is the research technique to be used. According to Anggapraja, (2016) it is the study performed on big and small populations, but the information examined is data from population samples. So that relative occurrences, distributions, and relationships between variables may be seen.

Population, Sample and Techniques for Sampling

The population is a generalization area of items or individuals that researchers introduced to be researched and then removed (Iii, 2013). The participants in this research were all 57 workers of the Bantul trading service. A sample is a portion of the population being represented or a subset of the population's characteristics (Iii, 2013). The model for this research included 57 members of the Bantul Trade Service's permanent staff group. Because training, self-efficacy, and creative problem solving are crucial in increasing team member performance. This study utilized saturated samples, items, and people with specific characteristics chosen to be examined and conclusions made. A sampling technique saturated with the number of 57 existing samples was utilized as the sampling method. According to Rosliani, ((2017) the sample withdrawal method is a representative sampling approach from the population; if the subject is fewer than 100, it is preferable to take them all so that the study is a population study. After then, depending on the number of topics, it may take between 10-15% or 20-25%.

Methods of Data Collection

Provided a customer to employees/employees of the Bantul Trade Office as research responders to collect information utilized by researchers.

RESULTS & DISCUSSION

Characteristics of Respondents

Table 1. Gender distribution of respondents.

	Gender	Frequency	Percent	Valid percent	Cumulative percent
Valid	Male	34	59,6	59,6	59,6
	Female	23	40,4	40,4	100,0
	Total	57	100,0	100,0	

Source: Processed primary data in 2022

According to the chart above, the Bantul District Trade Office's 57 workers are dominated by male employees, who account for 59.6% of the total, or 34 employees.

Table 2. Age Distribution of Respondents

Age	Frequency	Percent	Valid percent	Cumulative percent
20-30 Years	18	31,6	31,6	31,6
30-40 Years	20	35,1	35,1	66,7
40-50 Years	13	22,8	22,8	89,5
50-60 Years	6	10,5	10,5	100,0
Total	57	100,0	100,0	100

Source: Primary Data Processed in 2022

According to the chart of 57 workers, the Bantul District Trade Office is between 30 and 40, accounting for 35.1 percent of the total, or 20 employees.

Table 3. Respondents with Recent Education

Pendidikan	Frequency	Percent	Valid percent	Cumulative percent
SMA/SMK	26	45,6	45,6	45,6
DIPLOMA	7	12,3	12,3	57,9
SARJANA	19	33,3	33,3	91,2
MAGISTER	5	8,8	8,8	100,0
TOTAL	57	100,0	100,0	100

Source: Primary data collected in 2022

According to the findings of the table above, the Bantul District Trade Office has the most excellent domination with 57 workers, followed by Bachelor 33.3 percent with 19 employees.

Table 4. The number of people who responded per department.

Position	Frequency	Percent	Valid percent	Cumulative percent
Treasurer	1	1,8	1,8	1,8
Eselon 4	2	3,5	3,5	5,3
Head of sub section Uk	1	1,8	1,8	7,0
Head of Promotion	1	1,8	1,8	8,8
Cashier	1	1,8	1,8	10,5
PHL	3	5,3	5,3	15,8
Facilities and Infrastructure	1	1,8	1,8	17,5
Secretary	1	1,8	1,8	19,3
Staff	44	77,2	77,2	96,5
Staff of PAK	1	1,8	1,8	98,2
Staff of UK	1	1,8	1,8	100,0

Total	57	100,0	100,0	100
--------------	-----------	--------------	--------------	------------

Source: Primary data processed in 2022

Based on the position of the table's findings, the Bantul District Trade Office's 57 workers are controlled by a staff of 77.2 percent, totaling 44 employees.

Testing for Normalcy

Table 5. Normality Test

One-Sample Kolmogorov-Smirnov Test			Unstandardized Residual
N			57
Normal Parameters ^{a,b}	Mean		,0000000
	Std. Deviation		3,45014475
Most Extreme Differences	Absolute		,137
	Positive		,108
	Negative		-,137
Test Statistic			,137
Asymp. Sig. (2-tailed)			,009 ^c
Monte Carlo Sig. (2-tailed)	Sig.		,223 ^d
	99% Confidence Interval	Lower Bound	,212
		Upper Bound	,234

Source: Primary Data Processed 2022

The residual regression model seems to be regularly distributed, according to the table above. The Monte Carlo sig. (2-tailed) value is higher than 0.05, indicating it. The Monte Carlo sig. (2-tailed) result of 0.223, which equals $0.223 > 0.05$, demonstrates this.

Test F

Table 6. Test F

ANOVA^a

Model		Sum of Squares	Df	Mean Square	F	Sig.
1	Regression	1183.334	3	394.445	31.362	.000 ^b
	Residual	666.596	53	12.577		
	Total	1849.930	56			

a. Dependent Variable: Employee Performance

b. Predictors: (Constant), Creative Problem Solving, Training, Self Efficacy

Source: Primary data processed in 2022

The value of F is 31.362 with a significance value of $0.000 < 0.05$. According to the table above 7, the research model built is self efficacy, training and creative problem solving, training together has an influence on employee performance.

Multiple Linear Regression Analysis (MLRA) is a statistical technique for analyzing multiple

Table 7. Multiple Linear Regression

Model		Coefficients ^a				
		Unstandardized Coefficients		Standardized Coefficients	t	Sig.
		B	Std. Error	Beta		
1	(Constant)	-1.361	4.620		-.294	.770
	Pelatihan	.210	.141	.171	1.484	.144
	Self Efficacy	.492	.188	.407	2.625	.011
	Creative Problem Solving	.805	.361	.303	2.227	.030

a. Dependent Variable: Prestasi Karyawan

Source: Primary data processed in 2022

H1: Training has no discernible beneficial impact on team member performance. That is shown by the fact that the value of t calculate training variables is 1,484, while the value of the t table is 0.005. Df = 55 (57-2) is 1,673, implying that t calculate t table (1,484 1,673). The significance level is 0.144, which indicates that it is higher than 0.005. Employees at the Bantul Trade Office are not receiving training tailored to their requirements, making it ineffective in improving work performance in certain Bantul Trade Service employees.

H2: Employee performance is influenced by self-efficacy favorably and substantially. This is shown by the fact that the self-efficacy variable count is 2,625, while the t table value is 0.005 and the df = 55 (57-2) is 1,673, implying that t calculated $>$ t table (2,625 $>$ 1,673). The value of significance is 0.011, which is less than 0.005.

H3: Employee performance is positively affected by problem-solving. T indicates that the value t calculates the creative problem solving variable is 2,227, while the value of table T is 0.005 and df = 55 (57-2) is 1,673, implying that t calculates the table $>$ t (2,227 $>$ 1,673). The significance level is 0.030, which indicates that it is less than 0.005.

H4: Training, Self-Efficacy, and Problem-Solving Creativity Employee performance are influenced by simultaneous problem-solving in a good and substantial way. If the value of F is 31.362, and the significance value is $0.000 < 0.005$; this may be observed.

Table 8. Hypothesis Test

Hypotheses		T-Hitung	F	Sig	Information
H1	Training → Employee Performance	1.484	-	.144	rejected
H2	Self Efficacy → Employee Performance	2.625	-	.011	accepted
H3	Creative Problem Solving → Employee Performance	2.227	-	.030	accepted
H4	Training, Self Efficacy, Creative Problem Solving → Employee Performance	-	31.362	.000 ^b	accepted.

Source: Primary data processed in 2021

DISCUSSION

The results indicate that training has no significant effect on employee performance. The research findings contradict previous research (Annalia, 2020; Elisa & Sari, 2014; Yusnita & Fadhil, 2015) showing the finding that training has a significant effect on employee performance. The research findings demonstrate that self-efficacy has a significant effect on employee performance. This study is backed up by Hidayat & Setiawan, (2018) revealing that self-efficacy has a favorable and substantial impact on team member performance at PT. Tomo Food Industry in Sumedang. This is in line with Ardi et al., (2017) that one's belief in success is the most important driving factor so that the individual has an attitude not to give up easily. Besides, he or she is willing to work harder and has stable emotional stability, clear goals and focuses on achieving goals to succeed. .

Moreover, the results also depicts that creative problem solving has a significant effect on employee performance. This study is in line with by Styoro Cahyo Wibowo (2013) finding that creative problem-solving factors have a favourable and substantial impact on team member performance in the Technician section at PT. State Electricity Industry (Persero) of Bojonegoro.

Finally, the results also reveal that there is a joint effect of training, creative problem solving and self-efficacy have a significant effect on employee performance. The more employees have the competencies needed by the company, the more they have a strong motivation to succeed and have a way of thinking ahead, creative and full of improvement innovations. Besides, they do also learn something new, so they will tend to have a good performance in solving work problems.

CONCLUSION

Training has no discernible impact on increasing staff productivity. According to employees at the Bantul Trade Office, exercise doesn't base on their requirements. Thus it is ineffective in improving work performance in certain Bantul Trade Service employees. As a result, if workers adapt their high level of training in the workplace, the degree of achievement of Bantul Trade

Service personnel will increase. Self-Efficacy Improves Employee Performance Positively and Significantly. That demonstrates that if workers at the Bantul Trade Office have a high degree of self-efficacy at work, they also have a high level of achievement. Team member Performance is Improved by Creative Problem Solving Positively and Significantly. That shows that workers have a high level of Creative Problem-Solving in the workplace. They have a high success rate in Bantul Trade Office Training, Self-Efficacy, and Creative Problem Solving, all of which have a positive and substantial impact on the achievements of team members. If the three free variables mentioned above may influence the bound variables, namely Employee Achievement, then the degree of Employee Achievement at the Bantul Trade Office can be affected.

REFERENCES

- Anggapraja, I. T. (2016). Pengaruh Penerapan Knowledge Management dan Pengembangan Sumber Daya Manusia terhadap Kinerja Karyawan PT Telkom Tbk. (Studi Explanatory Survey pada Karyawan Unit Human Capital Management PT Telkom Tbk.). *Jurnal Aplikasi Manajemen*, 14(1), 140–146. <https://doi.org/10.18202/jam23026332.14.1.15>
- Annalia, W. (2020). Peran Pelatihan Dalam Meningkatkan Kinerja Sumber Daya Manusia Di Masa Covid-19. *Liabilities (Jurnal Pendidikan Akuntansi)*, 3(3), 186–194. <https://doi.org/10.30596/liabilities.v3i3.5795>
- Antonio, T., Lanawati, S., Wiriana, T. A., & Christina, L. (2014). Correlations Creativity, Intelligence, Personality, and Entrepreneurship Achievement. *Procedia - Social and Behavioral Sciences*, 115(Licies 2013), 251–257. <https://doi.org/10.1016/j.sbspro.2014.02.433>
- Ardi, V. T. P., Astuti, E. S., & Sulisty, M. C. W. (2017). Pengaruh Self-Efficacy terhadap Employee Engagement dan Kinerja Karyawan (Studi pada Karyawan PT Telekomunikasi Indonesia Regional V Surabaya). *Jurnal Administrasi Bisnis*, 52(1), 163–172.
- Azis, D., & Rahardjo, B. (2021). Peningkatan Kinerja Karyawan Melalui on the Job Training Dan Off the Job Training Dimasa Pandemi Covid-19. *Management and Sustainable Development Journal*, 3(2), 81–89. <https://doi.org/10.46229/msdj.v3i2.313>
- Barba Aragón, M. I., Jiménez Jiménez, D., & Sanz Valle, R. (2014). Training and performance: The mediating role of organizational learning. *BRQ Business Research Quarterly*, 17(3), 161–173. <https://doi.org/10.1016/j.cede.2013.05.003>
- Beattie, S., Woodman, T., Fakehy, M., & Dempsey, C. (2016). The role of performance feedback on the self-efficacy-performance relationship. *Sport, Exercise, and Performance Psychology*, 5(1), 1–13. <https://doi.org/10.1037/spy0000051>
- Elisa, M. R. M. E., & Sari, N. I. (2014). Peranan Pelatihan Dalam Peningkatan Kinerja Karyawan (Studi Kasus Bagian Operasional PT PLN (PERSERO)). *Jurnal Orasi Bisnis*, XII, 92–106.
- Hertomo, Nurul Khastelia; Luturlean, B. S. (2020). Pengaruh Pelatihan Terhadap Kinerja Karyawan Kantor Pusat PT. Pos Indonesia (Persero) Bandung. *Jurnal Ilmiah Manajemen, Ekonomi, Dan Akuntansi (JIMEA)*, 4(1), 200–207.
- Hidayat, H., & Setiawan, I. A. (2018). Pengaruh Self Esteem Dan Self Efficacy Terhadap Kinerja Karyawan (Studi pada Karyawan PT. Tomo Food Industri, Sumedang) Herman. *Sains Manajemen Dan Akuntansi*, VIII(2), 65–85.

- Hidayatun, N. (2016). Problem Solving Sistem Penggajian Karyawan Dalam Manajemen Operasional Komputer Menggunakan Pendekatan Sistem. *Ijcit*, 1(2), 1–9.
- Iii, B. A. B. (2013). *Aini Qurrotullain, Penggunaan Metode Preview, Resd, Summarre, Test (PQRST) Dalam Meningkatkan Kemampuan Pada Siswa Tunarungu Universitas Pendidikan Indonesia | repository.upi.edu | perpustakaan.upi.edu.*
- Indrajita, I. K., Sadiartha, A. . N. G., & Mahayasa, I. G. A. (2021). Pengaruh Kreativitas dan Inovasi terhadap Kinerja Karyawan pada PT. Tohpati Grafika Utama Denpasar. *Jurnal Widya Amirta (Jurnal Manajemen Kewirausahaan Dan Pariwisata)*, 1(1), 1–13. <https://doi.org/10.32795/widyaamrita.v1i1.1142>
- Juwono, O., & Wangsadinata, Y. (2010). Kreativitas, Gaya Kepimpinan dan Kompetensi dalam Membentuk Kepuasan Kerja Karyawan. *The Winners*, 11(1), 55–65. <https://doi.org/10.21512/tw.v11i1.700>
- Khaerana, K. (2020). Pengaruh Self Efficacy terhadap Kinerja Pegawai pada Sekretariat Komisi Pemilihan Umum Daerah (KPU) Kabupaten Luwu Timur. *Jurnal Ecoment Global*, 5(1), 80. <https://doi.org/10.35908/jeg.v5i1.835>
- Kurniawan, M. (2019). Faktor-Faktor Yang Mempengaruhi Prestasi Kerja Karyawan Pada PT. Excelcomindo Engineering Indonesia Sumatera. *Jurnal Media Wahana Ekonomika*, 15(3), 39. <https://doi.org/10.31851/jmwe.v15i3.2888>
- Noviawati, D. R. (2016). Pengaruh Self Efficacy terhadap Kinerja Karyawan dengan Motivasi sebagai Variabel Intervening (Studi pada Karyawan Divisi Finance dan Human Resources PT. Coca-Cola Distribution Indonesia, Surabaya). *Jurnal Ilmu Manajemen*, 4(3), 1–12. <https://www.trijurnal.lemlit.trisakti.ac.id/semnas/article/viewFile/3339/2833>
- Rohayuningsih, H., Handoyo, E., & Artikel, I. (2015). Berpikir Kreatif dalam Pengambilan Keputusan. *Forum Ilmu Sosial*, 42(1), 106–113.
- Roslani, S. M. (2017). Pengaruh Pemberian Reward and Punishment Terhadap Motivasi Belajar Siswa Kelas X Pada Mata Pelajaran Pkn Di Sma Pasundan 3 Bandung. *NASPA Journal*, 33, 26–36.
- Saragih, S., & Siahaan, E. (2021). Pengaruh Stres Kerja, Efikasi Diri dan Kreatifitas Terhadap Kinerja Pegawai Badan Layanan Umum Daerah Rumah Sakit Umum Daerah Djasamen Saragih Pematangsiantar. *J-MIND (Jurnal Manajemen Indonesia)*, 6(2), 90. <https://doi.org/10.29103/j-mind.v6i2.5883>
- Sawitri, D., Cahyandari, N., & Muawanah, U. (2018). Hubungan Self Leadership, Self Efficacy dan Kecerdasan Intelektual Terhadap Kinerja Karyawan pada Badan Pendapatan Daerah Kabupaten Mojokerto. *Jurnal Manajemen Dan Bisnis Indonesia*, 6(1), 76–90. <https://doi.org/10.31843/jmbi.v6i1.184>
- Shaukat, H., Ashraf, N., & Ghafoor, S. (2015). Impact of Human Resource Management Practices on Employees Performance. *Middle-East Journal of Scientific Research*, 23(2), 329–338. <https://doi.org/10.5829/idosi.mejsr.2015.23.02.22117>
- Sitzmann, T., & Yeo, G. (2013). A Meta-Analytic Investigation of the Within-Person Self-Efficacy Domain: Is Self-Efficacy a Product of Past Performance or a Driver of Future Performance? *Personnel Psychology*, 66(3), 531–568. <https://doi.org/10.1111/peps.12035>
- Styoro Cahyo Wibowo, A. (2013). Pengaruh Pelatihan Dan Kreativitas Terhadap kinerja Karyawan Bagian Teknisi Pada Pt. Perusahaan Listrik Negara (Persero) Area Bojonegoro. *Jurnal Ilmu Manajemen (JIM)*, 1(4).
- Widyawaty Mashar. (2014). Jurnal pengaruh pelatihan terhadap prestasi kerja pegawai pada

inspektorat kabupaten rokan hulu. *Jurnal Pengaruh Pelatihan Terhadap Prestasi Kerja Pegawai Pada Inspektorat Kabupaten Rokan Hulu*, 151.

Yusnita, N., & Fadhil, F. (2015). Pengaruh Pelatihan Karyawan Terhadap Kinerja Karyawan Pada Cv Cibalong Happy Land Bogor. *JIMFE (Jurnal Ilmiah Manajemen Fakultas Ekonomi)*, 1(1), 1–5. <https://doi.org/10.34203/jimfe.v1i1.440>

Zaki, W., Ali, A., Bakar, A., & Sarwar, B. (2019). Role of self-efficacy in the relationship of training and employee performance. *Paradigms*, 13(1), 67–74. <https://doi.org/10.24312/1800077130111>